

Do Secondary Orbital Interactions Really Exist?

JOSÉ I. GARCÍA, JOSÉ A. MAYORAL, AND
LUIS SALVATELLA*

*Departamento de Química Orgánica, Instituto de Ciencia de
Materiales de Aragón, Facultad de Ciencias,
CSIC–Universidad de Zaragoza, E-50009 Zaragoza, Spain*

Received February 2, 2000

ABSTRACT

A revision of the most typical examples used to illustrate the existence of secondary orbital interactions (SOI) has been achieved. However, our analysis indicates that no conclusive evidence can be obtained from these cases. All five examples proposed by Woodward and Hoffmann in *The Conservation of Orbital Symmetry* have been revisited. A combination of well-known mechanisms (such as solvent effects, steric interactions, hydrogen bonds, electrostatic forces, and others) can be invoked instead to justify the endo/exo selectivity of Diels–Alder reactions.

1. Introduction

The statement of the orbital symmetry rules by Woodward and Hoffmann constitutes one of the most important highlights in modern theoretical chemistry.^{1,2} The fundamentals of these principles lie in the different possibilities for overlap between frontier molecular orbitals in pericyclic reactions. According to the orbital symmetry rules, a process is allowed when the lobes of the atomic orbitals involved in the breakage or formation of σ bonds have the same wave function sign. The existence of these interaction mechanisms (known as first-order orbital interactions) allows us to explain why concerted reactions proceed easily when certain conditions are met.²

The reaction rate as well as several types of selectivity (such as regio- and stereoselectivity) of allowed pericyclic processes can be significantly modified by the environment of the active centers, and these effects are known

José I. García was born in Zaragoza, Spain, in 1959. He obtained a Ph.D. in 1986 at the University of Zaragoza. After postdoctoral research at the Institut de Topologie et de Dynamique des Systèmes of the CNRS–Université de Paris VII, he joined the Instituto de Ciencia de Materiales de Aragón as a tenured scientist of the CSIC. His main research interest is in molecular aspects of stereoselective organic reactions, with particular emphasis on asymmetric catalysis and solvent effects.

José A. Mayoral was born in Zaragoza, Spain, in 1956. He obtained a Ph.D. at the University of Zaragoza and was appointed to the post of Assistant Professor in 1983. In 1986 he was promoted to the post of Permanent Professor of Organic Chemistry in the University of Zaragoza. He is particularly interested in asymmetric synthesis, especially uncommon aspects such as the application of solid catalysts to synthesis and immobilization of chiral catalysts, as well as different mechanistic aspects of organic chemistry.

Luis Salvatella was born in Girona, Spain, in 1967. After obtaining his Ph.D. in chemistry from the University of Zaragoza in 1994, he spent two years undertaking postdoctoral research work under the supervision of Dr. Ruiz-López at the University of Nancy I (France). He is currently an Assistant Professor at Zaragoza University, where he is preparing a Ph.D. thesis in history on the reception of stereochemistry in Spain (1874–1930). His main interests deal with the modeling of organic reactivity.

Scheme 1

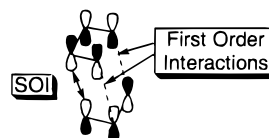

as second-order orbital interactions. According to Gleiter and Böhm, these effects can be classified as substituent, polar group, and secondary orbital interactions (SOI).³ Whereas substituent and polar group effects have general applicability in organic chemistry, the latter interactions are restricted to pericyclic reactions. SOI occur because of the overlap between pairs of atomic orbitals involved in the reorganization of the π system, but which do not participate in the breakage or formation of σ bonds (Scheme 1). It should be noted that this description allows us to disregard some cases (such as the cycloadditions of 4-phenyl-1,2,4-triazoline-3,5-dione with some propellane dienes)⁴ that had been previously considered as typical examples of the existence of SOI.

It can be observed that SOI constitute a very subtle type of effects. On one hand, the magnitude of the interaction energies implicated is relatively small. For example, a product ratio = 80:20 corresponding to a reaction carried out at 25 °C involves an energy difference between the transition states of 0.8 kcal mol⁻¹. On the other hand, SOI should present a very restricted action field, since they are assumed to appear during the reaction process, whereas stable compounds showing these effects are not known.

Since the proposal of SOI in 1965,^{5,6} these interactions have been extensively invoked to explain the stereoselectivity of a large number of pericyclic reactions. Thus, a review of this subject in 1983 contains 131 references.⁷ There are, arguably, few recent examples of a theory that has become so widely accepted with so little clear experimental evidence to support it. As we will discuss later, the existence of SOI was first based on a few experimental examples whose reliability was far from satisfactory. Since then, the great success of the orbital symmetry rules has acted to recruit new SOI supporters. For a long time it seemed that both mechanisms (first-order orbital interactions and SOI) came under the same umbrella, so that if one supported the former theory, the latter would also have to be sustained. Thus, SOI have often been invoked, with other simpler reasons discarded, to explain selectivity results in a wide variety of reactions. Even worse, as we will discuss below, SOI have been invoked in some cases to interpret experimental data that were found to be erroneous, and such interpretations have been held for a long time to be “typical” examples of SOI.

A careful analysis of the scientific literature has led us to believe that the results for which SOI have been invoked could be reinterpreted in terms of well-known mechanisms. Indeed, we think that conclusive evidence for the

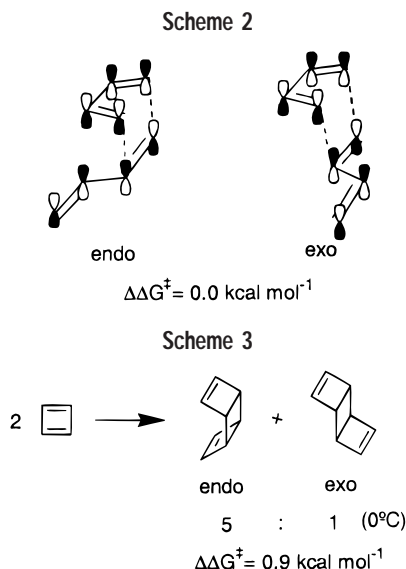

existence of these interactions has never been presented. In the following sections we outline our reasoning for this belief.

2. Is the Hypothesis of SOI Currently Justified?

The arguments used by Woodward and Hoffmann in the proposal of SOI are described in their book, *The Conservation of Orbital Symmetry*.² A detailed revision of all five examples described therein shows that the hypothesis of SOI is not sufficiently supported in terms of our current knowledge of chemistry.

Thus, the dimerization of butadiene was chosen as a paradigm model to explain the nature of SOI (Scheme 2). However, experimental results have shown that this choice was very unfortunate, since no significant endo preference is found for this reaction.⁸

On the other hand, results on the dimerization of cyclobutadiene were known at that time, and this reaction shows a significant endo preference (Scheme 3),⁹ though no experimental mechanistic study has been reported up to date. Instead, a theoretical study has thrown some light on this subject.¹⁰ Thus, neither RHF nor CASSCF methodologies (with a 3-21G basis set) have allowed the localization of a transition structure for the concerted mechanism leading to the major adduct, whereas the transition state corresponding to the stepwise pathway has been characterized. Since these techniques have been successfully used in the characterization of the alternative mechanistic pathways of other cycloadditions,^{11,12} it can be concluded that the formation of the endo adduct takes place through a stepwise mechanism. Considering that Woodward–Hoffmann rules are valid only for concerted reactions, SOI cannot be invoked for the cyclobutadiene dimerization.

The most striking corollaries of the hypothesis of SOI were obtained when an exo preference was predicted. Such a prediction was made for the [4 + 3] cycloaddition between butadiene and the allyl cation on the basis of LUMO_{diene}–HOMO_{cation} repulsive interactions (Scheme 4).

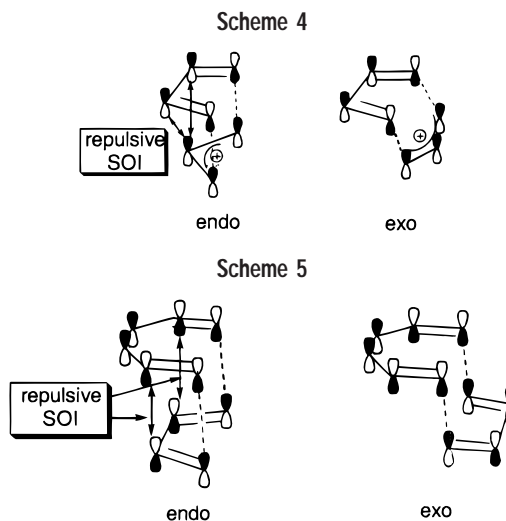

However, both theoretical (at the HF/6-31G* level)¹³ and experimental results (for an intramolecular [4 + 3] cycloaddition)¹⁴ agree with a stepwise mechanism. Therefore, SOI cannot play a role in the butadiene + allyl cation reaction.

Another prediction of an exo preference was obtained for the [6 + 4] cycloaddition between *cis*-hexatriene and butadiene. However, this conclusion cannot be contrasted with experimental data since no such work has been reported, probably due to technical difficulties derived from the concurrence of more favored reactions (such as [4 + 2] cycloadditions).

Instead, B3LYP/6-31G* calculations on the parent [6 + 4] cycloaddition indicate a concerted mechanism with a significant exo preference (1.1 kcal mol⁻¹),¹⁵ and this has been attributed to the presence of repulsive SOI (Scheme 5). However, a different interpretation, based on the results obtained in an unpublished theoretical study, can be proposed. Thus, we have studied both “endo” and “exo” conformers of the reaction adduct (i.e., conformations resulting from the corresponding approaches of the [6 + 4] cycloaddition) at the same theory level by means of the Gaussian94 program¹⁶ (Figure 1). The results indicate a greater stability for the “exo” conformer (total energy = –389.4196 hartrees) relative to the corresponding “endo” one (total energy = –389.4155 hartrees) by 2.6 kcal mol⁻¹. Since SOI cannot be applied to the relative stability of ground-state compounds, this energy difference must be attributed to nonbonding interactions. The simple application of the Bell–Evans–Polanyi principle (for similar reactions, the more exothermic process will have the lower activation energy) allows us to attribute the greater stability of the exo transition structure to nonbonding interactions, with the SOI hypothesis being unnecessary in this explanation. Furthermore, the magnitude of the exo preference in the transition structures (slightly less than half the value obtained for the adduct conformers) agrees with the reactant-like character of the transition states, according to the Marcus equation.

The remaining example proposed by Woodward and Hoffmann to support the SOI is based on the preference for a chair conformation, rather than the boat form, in

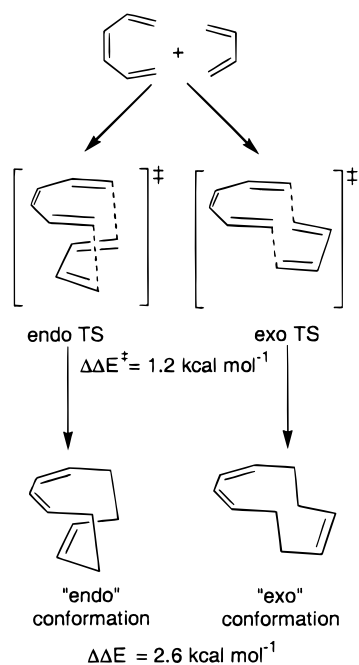
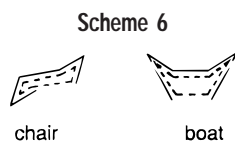

FIGURE 1. Comparison of endo and exo approaches for the [6 + 4] cycloaddition between *cis*-hexatriene and butadiene.



the transition states of the Cope rearrangement (Scheme 6). However, an experimental study on the effect of phenyl substituents has shown that the energy difference between boat and chair transition states cannot be justified in terms of these interactions.¹⁷ In fact, a simple force field model that takes into account only nonbonding steric interactions (MM2) is able to justify the differing stabilities of the two transition states.

In summary, it can be concluded that if sufficient experimental or theoretical evidence were known at that time, serious doubts regarding the effectiveness of SOI would surely have been raised. Consequently, this mechanism would not have gained as much wide acceptance among chemists as it did.

3. The Origins of the Endo/Exo Selectivity in Diels–Alder Reactions

The successful prediction of an endo preference for a large number of Diels–Alder reactions has been usually considered as one of the greatest exploits of the hypothesis of SOI.¹⁸ However, theoretical studies reveal that the atoms presumed to be involved in the SOI are situated relatively far (ca. 2.8 Å) in the corresponding transition structures.^{19–26} This fact should be considered as strong evidence against the existence of these interactions, since the calculated geometries for transition states of Diels–Alder reactions have allowed us to ascertain the presence of other attractive effects, such as the [4 + 3] interactions occurring between an electron-deficient atom and an incipient σ bond.^{25,27} It should be remarked that [4 + 3] interactions

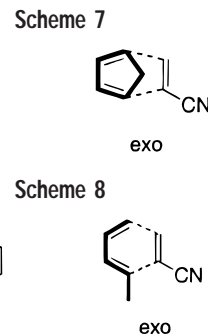

are not a particular type of SOI, but a special kind of substituent effect, according to the classification of Gleiter and Böhm.³

Analysis of the endo/exo selectivity in a number of Diels–Alder reactions of relatively simple reactants allows us to conclude that the assumed effects of SOI can instead be attributed to a combination of well-known interaction mechanisms (such as solvent effects, steric interactions, hydrogen bonds, and electrostatic forces).

3.1. Solvent Effects. A major challenge exists in the elucidation of the origins of the endo/exo selectivity found in experimental studies of Diels–Alder cycloadditions carried out in solution. This difficulty involves the separation of solvent effects from the “inherent” selectivity corresponding to the gas-phase reactions. Thus, it is well known that an increase in the solvent polarity induces an increase in the endo/exo ratio in a number of common Diels–Alder reactions.²⁸ In some cases, solvent effects can even be considered as the source of the endo preference in solution.

The cyclopentadiene + acrylonitrile reaction can be regarded as a typical example of an endo preference induced by the effect of the medium (Scheme 7). Indeed, B3LYP/6-31G*²⁹ and MP3/6-31G**/HF/6-31G*²¹ calculations for the gas-phase cycloaddition as well as experimental data for the reaction in nonpolar solvents^{30,31} indicate a very slight exo preference (by 0–0.4 kcal mol⁻¹). Experimental^{30–32} as well as theoretical studies^{33–35} indicate that the polarity of the medium causes an increase in the endo/exo ratio of this reaction. As a consequence, an endo preference is found when the reaction is carried out in a large number of common solvents.^{30–32}

The Diels–Alder cycloaddition between acrylonitrile and piperylene follows a behavior pattern similar to that of the corresponding reaction with cyclopentadiene (Scheme 8).³⁶ Thus, a preference for the ortho-trans adduct (corresponding to an exo approach) is found in benzene solution, whereas the ortho-cis product (formed via an endo transition state) is favored in polar solvents (e.g., methanol, ethanol, and acetone).

3.2. Steric Interactions. It is currently widely accepted that steric interactions can play a role in the endo/exo selectivity of Diels–Alder reactions. For example, the endo preference observed in the cycloadditions of cyclopentadiene with some alkenes (such as cyclopentene or *cis*-3,4-dichlorocyclobutene) is generally attributed to steric repulsion between the methylene group of the diene and the substituents of the dienophile.³⁷ However, it can be

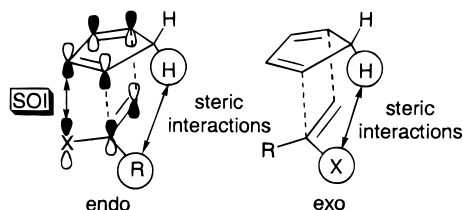
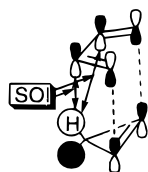

FIGURE 2. Alternative interactions proposed in order to explain the endo preference found in the Diels–Alder reactions of cyclopentadiene with some dienophiles.

Table 1. Endo Percentage and Relative Activation Enthalpy (Endo/Exo) of the Diels–Alder Reactions of Cyclopentadiene with Various Dienophiles

R	X	% endo (at 25 °C)	$\Delta\Delta H^\ddagger$ (kcal mol ⁻¹)
H	COOH	80.2	0.65 ± 0.01
CH ₃	COOH	29.2	-0.74 ± 0.01
H	CHO	74.4	0.57 ± 0.06
CH ₃	CHO	17.0	-1.21 ± 0.04
H	COOCH ₃	74.3	0.56 ± 0.04
CH ₃	COOCH ₃	30.1	-0.25 ± 0.08

Scheme 9



argued that the endo preference of Diels–Alder reactions of cyclopentadiene with a number of α,β -unsaturated carbonyl compounds could also be justified in terms of SOI (Figure 2).¹⁸ Nevertheless, experimental data (shown in Table 1) indicate that a methyl group induces a greater endo preference than carbonyl-bearing substituents (COOH, CHO, COOCH₃).³⁸ This result seems in better accord with the larger size of the methyl group as deduced from experimental data on the axial/equatorial conformational equilibria in cyclohexane derivatives.³⁹

3.3. Hydrogen Bonds. One of the most interesting cases of endo/exo selectivity is the preferential formation of the endo adduct (the only stereoisomer detected by NMR) in the cycloaddition reaction between butadiene and cyclopropene.⁴⁰ This result has been attributed to a stabilizing interaction between the central carbons of the diene and the methylene group of cyclopropene.^{41–45} Apeloig and Matzner have carried out a theoretical study on the reactions of cyclopropene with a number of dienes.⁴¹ In that work, the authors attributed the endo/exo selectivity to the existence of SOI in a LUMO_{diene}–HOMO_{dienophile} interaction (Scheme 9). The good correlation that exists between a certain magnitude calculated for the endo transition structures (the square of the Mulliken overlap population divided by the energy gap between the frontier orbitals involved) and the endo/exo selectivity was considered to represent evidence for the existence of SOI.

However, this interpretation was subsequently called into question since such interactions should obey a linear relationship with the Mulliken population.⁴² In an alternative theoretical study into the reactions of cyclopropene with open-chain dienes, it was shown that the endo/exo

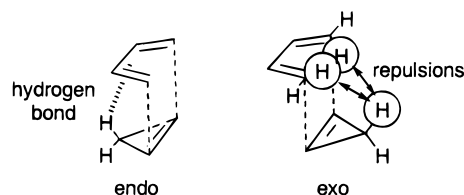
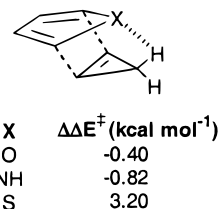

FIGURE 3. Alternative interactions proposed in order to explain the endo preference found in the Diels–Alder reaction between butadiene and cyclopropene.

Scheme 10



selectivity can be attributed to a combination of electron delocalization and electrostatic forces. In our opinion, such a mixture of effects may be consistent with the existence of a hydrogen bond between the atoms involved. In fact, such an interaction has already been proposed for the reaction between butadiene and cyclopropene (Figure 3).⁴³ Furthermore, crystallographic results have shown that the methylene group of cyclopropene is a strong C–H hydrogen bond donor, similar to acetylenic C–H groups.⁴⁶

Another alternative, complementary explanation involves the existence of a destabilizing interaction in the exo transition state that arises from the repulsion (due to electrostatic and/or van der Waals interactions) between a hydrogen atom of the methylene group of cyclopropene and the inner hydrogen atoms of butadiene (situated at a distance of 2.3 Å, according to HF/6-31G* calculations),⁴² as shown in Figure 3. This mechanism is discussed in more detail in the next section.

The ability of cyclopropene to form hydrogen bonds in the transition structures of Diels–Alder reactions is supported by high-level calculations (such as MP2/6-31G*⁴¹ or B3LYP/6-31+G*)⁴⁵ for cycloadditions with some heterocycles. Thus, the exo preference predicted for the reactions of cyclopropene with furan, pyrrole, and other related compounds^{41,45,47} suggests the presence of a hydrogen bond between cyclopropene and the bridge heteroatom (Scheme 10). The greater affinity of hydrogen bonds for nitrogen and oxygen in comparison with π systems is consistent with the exo preference calculated. Furthermore, the greater stability of the endo transition structure predicted for the thiophene + cyclopropene reaction^{41,47} agrees with the low propensity of sulfur to act as an acceptor of hydrogen bonds. The presence of such interactions between the diene and the dienophile has also been proposed in other Diels–Alder reactions.⁴⁸ Anyway, a deeper investigation into the butadiene + cyclopropene cycloaddition would be necessary to ascertain the nature of the interactions existing between the reactants.

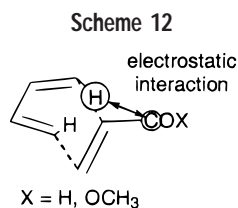
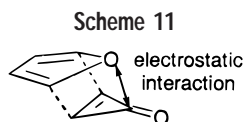

3.4. Electrostatic Forces. The furan + cyclopropanone cycloaddition is probably the clearest example of the influence of electrostatic interactions on the endo/exo selectivity of Diels–Alder reactions. Thus, the high exo preference predicted by MP4SDQ/6-31G* energy calculations on MP2/6-31G*-optimized geometries (1.8 kcal mol⁻¹) has been attributed to the existence of a strong electrostatic stabilization between the furan oxygen and the carbonyl carbon of cyclopropanone (Scheme 11).⁴⁹ The short distance between these atoms in the exo transition structure (2.7 Å) provides justification of the results obtained.

In our opinion, the endo/exo selectivity predicted by theoretical calculations for other Diels–Alder reactions can also be explained in terms of electrostatic forces. For example, the slight endo preferences calculated for the reactions of butadiene with simple α,β -unsaturated carbonyl compounds (such as acrolein²⁵ or methyl acrylate²⁴) can be attributed to electrostatic repulsions existing in the exo transition states between the positive charges corresponding to the “in” hydrogens of butadiene and the carbonyl carbon of the dienophile (Scheme 12). This mechanistic interaction offers an alternative explanation to the hypothesis of SOI.

The hypothesis of electrostatic forces allows a new view to be taken regarding the increase in endo/exo selectivity induced by Lewis acids. According to the theory of SOI, such a variation can be attributed to an increase in the atomic orbital coefficient of the carbonyl carbon corresponding to the LUMO of the dienophile. However, this result can also be explained in terms of our hypothesis by assuming an increase in the positive charge on the carbonyl carbon induced by the coordination of the Lewis acid (Scheme 12).

The very high enthalpic preference predicted by B3LYP/6-31G* calculations for the endo transition structure of the isoprene + maleic anhydride reaction (1.9 kcal mol⁻¹)²³ can be attributed to the particularly short distances that exist between the “in” hydrogens of isoprene and the corresponding nearest carbonyl carbon atoms (2.6 Å) of the dienophile (Scheme 13). This explanation can also be put forward to explain the high endo preference (1.2 kcal mol⁻¹)⁸ found experimentally for the butadiene + maleic anhydride reaction. Nevertheless, further research on this subject would evidently be welcome.

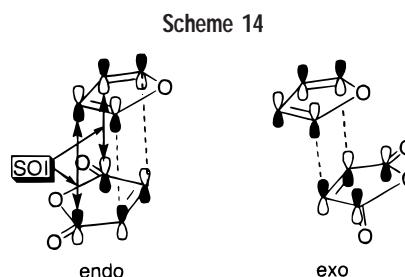
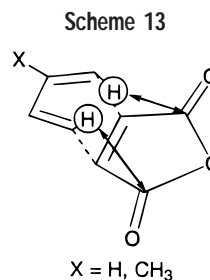

4. The Furan + Maleic Anhydride Cycloaddition

The Diels–Alder reaction between furan and maleic anhydride warrants particular comment. In recent years, the spectacular kinetic endo preference (3.8 kcal mol⁻¹)⁵⁰ described for this cycloaddition has been considered to constitute a fundamental piece of evidence for the existence of SOI (see Scheme 14). Indeed, the lack of significant steric repulsions between the reactants, along with the presence of two such interactions in the endo transition state, has made this case a representative example of SOI.¹⁸

However, the reinvestigation into the stereochemical course of this reaction has turned this picture on its head. On one hand, experimental studies have shown that the previously described endo preference was in error,^{51,52} with the endo transition state being only slightly favored in comparison with the analogous exo state (0.2 kcal mol⁻¹).²⁶ On the other hand, MP2/6-31G* calculations have indicated that secondary charge transfer between the reactants does not take place.²⁶ The authors concluded that the small endo preference of this reaction is due to dispersion forces.

5. Conclusions

We have shown that the hypothesis of SOI is not necessary to explain the stereoselectivity results found in pericyclic reactions. We believe that a combination of well-known mechanisms (such as solvent effects, steric interactions, hydrogen bonds, electrostatic forces, and others) can be put forward in their place.

The positive activation barriers found for pericyclic reactions can be ideally decomposed in destabilizing and stabilizing terms. The main destabilizing terms comes from the closed-shell repulsion between the atoms involved in bond formation, due to their mutual closeness in the transition states. On the other hand, the very same atoms are also involved in the main stabilizing term, namely the first-order orbital interactions, which are

subject to symmetry conditions. The balance between attractive and repulsive energy terms leads to the bond distortion and angle changes on going from reagents to transition states. Obviously, the destabilizing contributions are larger than the stabilizing ones in the transition states. The extrapolation of this conclusion to the atom approximations involved in SOI could allow us to explain the lack of conclusive evidence for the existence of such interactions.

It is clear that it could be argued that we have not demonstrated the nonexistence of SOI. However, it is logically impossible to demonstrate that something does not exist, as the scholastic philosophers knew well. Only the existence of something could be argued. As scientists, our task is to accumulate unequivocal evidence (both experimental and theoretical) that supports the existence of SOI and to clearly delimit their field of action and their importance relative to other interaction mechanisms. We hope that the considerations gathered in this Account can help to stimulate theoretical and experimental studies aimed at this goal, as well as to establish the kind of mechanisms against which SOI should be compared and evaluated. Until the hypothesis of SOI is unequivocally demonstrated, however, we believe that Occam's razor⁵³ should be used to eliminate them from the chemical literature.

Financial support of the Comisión Interministerial de Ciencia y Tecnología (Project MAT99-1176-CO2-01) is acknowledged. The authors thank Dr. D. Suárez for helpful comments on the manuscript.

References

- Berson, J. A. Discoveries Missed, Discoveries Made: Creativity, Influence, and Fame in Chemistry. *Tetrahedron* **1992**, *48*, 1–17.
- Woodward, R. B.; Hoffmann, R. *The Conservation of Orbital Symmetry*; Academic Press: New York, 1970.
- Gleiter, R.; Böhm, M. C. Regio- and Stereoselectivity in Diels–Alder Reactions. Theoretical Considerations. *Pure Appl. Chem.* **1983**, *55*, 237–244.
- Gleiter, R.; Ginsburg, D. Propellanes. XLVI. Steric and Electronic Effects as Observed in Reactions of Propellanes. *Pure Appl. Chem.* **1979**, *51*, 1301–1315.
- Hoffmann, R.; Woodward, R. B. Orbital Symmetries and Endo-Exo Relationships in Concerted Cycloaddition Reactions. *J. Am. Chem. Soc.* **1965**, *87*, 4388–4389.
- Hoffmann, R.; Woodward, R. B. Orbital Symmetries and Orientational Effects in a Sigmatropic Reaction. *J. Am. Chem. Soc.* **1965**, *87*, 4389–4390.
- Ginsburg, D. The Role of Secondary Orbital Interactions in Control of Organic Reactions. *Tetrahedron* **1983**, *39*, 2095–2135.
- Stephenson, L. M.; Smith, D. E.; Current, S. P. Endo Preference in the Diels–Alder Cycloaddition of Butadiene and Maleic Anhydride. *J. Org. Chem.* **1982**, *47*, 4170–4171.
- Watts, L.; Fitzpatrick, J. D.; Pettit, R. On the Nature of the Ground State of Cyclobutadiene. *J. Am. Chem. Soc.* **1966**, *88*, 623–624.
- Li, Y.; Houk, K. N. The Dimerization of Cyclobutadiene. An ab Initio CASSCF Theoretical Study. *J. Am. Chem. Soc.* **1996**, *118*, 880–885.
- Houk, K. N.; Li, Y.; Evanseck, J. D. Transition Structures of Hydrocarbon Pericyclic Reactions. *Angew. Chem., Int. Ed. Engl.* **1992**, *31*, 682–708.
- Houk, K. N.; Li, Y.; Storer, J.; Raimondi, L.; Beno, B. Concerted and Stepwise Mechanisms in Cycloaddition Reactions: Potential Surfaces and Isotope Effects. *J. Chem. Soc., Faraday Trans.* **1994**, *90*, 1599–1604.
- de Pascual-Teresa, B.; Houk, K. N. The Ionic Diels–Alder Reaction of the Allyl Cation and Butadiene: Theoretical Investigation of the Mechanism. *Tetrahedron Lett.* **1996**, *37*, 1759–1762.
- Gassman, P. G.; Gorman, D. G. Stepwise Mechanism for the formation of $2\pi + 4\pi$ Cycloadducts in the Ionic Diels–Alder Reaction. *J. Am. Chem. Soc.* **1990**, *112*, 8624–8626.
- Goldstein, E.; Beno, B. R.; Houk, K. N. Transition Structures and Exo/Endo Stereoselectivities of Concerted [6+4] Cycloadditions with Density Functional Theory. *Theor. Chem. Acc.* **1999**, *103*, 81–84.
- Frisch, M. J.; Trucks, G. W.; Schlegel, H. B.; Gill, P. M. W.; Johnson, B. G.; Robb, M. A.; Cheeseman, J. R.; Keith, T. A.; Petersson, G. A.; Montgomery, J. A.; Raghavachari, K.; Al-Latham, M. A.; Zakrzewski, V. G.; Ortiz, J. V.; Foresman, J. B.; Cioslowski, J.; Stefanov, B. B.; Nanayakura, A.; Challacombe, M.; Peng, C. Y.; Ayala, P. Y.; Chen, W.; Wong, M. W.; Andrés, J. L.; Replogle, E. S.; Gomperts, R.; Martin, R. L.; Fox, D. J.; Binkley, J. S.; Defrees, D. J.; Baker, J.; Stewart, J. J. P.; Head-Gordon, M.; González, C.; Pople, J. A. *Gaussian94* (Revision C.2); Gaussian Inc.: Pittsburgh, PA, 1995.
- Shea, K. J.; Stoddard, G. J.; England, W. P.; Daffner, C. D. Origin of the Preference for the Chair Conformation in the Cope Rearrangement. Effect of Phenyl Substituents on the Chair and Boat Transition States. *J. Am. Chem. Soc.* **1992**, *114*, 2635–2643.
- Sauer, J.; Sustmann, R. Mechanistic Aspects of Diels–Alder Reactions: A Critical Survey. *Angew. Chem., Int. Ed. Engl.* **1980**, *19*, 779–807.
- Loncharich, R. J.; Brown, F. K.; Houk, K. N. Transition Structures of the Diels–Alder Reaction of Butadiene with Acrolein. *J. Org. Chem.* **1989**, *54*, 1129–1134.
- Birney, D. M.; Houk, K. N. Transition Structures of the Lewis Acid-Catalyzed Diels–Alder Reaction of Butadiene with Acrolein. The Origins of Selectivity. *J. Am. Chem. Soc.* **1990**, *112*, 4127–4133.
- Jorgensen, W. L.; Lim, D.; Blake, J. F. Ab Initio Study of Diels–Alder Reactions of Cyclopentadiene with Ethylene, Isoprene, Cyclopentadiene, Acrylonitrile, and Methyl Vinyl Ketone. *J. Am. Chem. Soc.* **1993**, *115*, 2936–2942.
- Ruiz-López, M. F.; Assfeld, X.; García, J. I.; Mayoral, J. A.; Salvatella, L. Solvent Effects on the Mechanism and Selectivities of Asymmetric Diels–Alder Reactions. *J. Am. Chem. Soc.* **1993**, *115*, 8780–8787.
- Beno, B. R.; Houk, K. N.; Singleton, D. A. Synchronous or Asynchronous? An “Experimental” Transition State from a Direct Comparison of Experimental and Theoretical Kinetic Isotope Effects for a Diels–Alder Reaction. *J. Am. Chem. Soc.* **1996**, *118*, 9984–9985.
- García, J. I.; Mayoral, J. A.; Salvatella, L. An Ab Initio Study on the Conformational and Endo/exo Preferences of Acrylates in Diels–Alder Reactions. *Tetrahedron* **1997**, *53*, 6057–6064.
- García, J. I.; Martínez-Merino, V.; Mayoral, J. A.; Salvatella, L. Density Functional Theory Study of Lewis Acid-Catalyzed Diels–Alder Reactions. The Butadiene + Acrolein Paradigm. *J. Am. Chem. Soc.* **1998**, *120*, 2415–2420.
- Calvo-Losada, S.; Suárez, D. Stereochemistry of the Furan–Maleic Anhydride Cycloaddition: A Theoretical Study. *J. Am. Chem. Soc.* **2000**, *122*, 390–391.
- Singleton, D. A. A [4+3] Transition State for a [4+2] Cycloaddition. A New Secondary Orbital Interaction in Diels–Alder Reactions. *J. Am. Chem. Soc.* **1992**, *114*, 6563–6564.
- Cativiela, C.; García, J. I.; Mayoral, J. A.; Salvatella, L. Modelling of Solvent Effects on the Diels–Alder Reaction. *Chem. Soc. Rev.* **1996**, *25*, 209–218.
- Jursic, B. S. Comparison of AM1 and Density Functional Theory-Generated Transition State Structures and Activation Energies for Cyanoalkenes Addition to Cyclopentadiene. *J. Mol. Struct. (THEOCHEM)* **1995**, *358*, 139–143.
- Nakagawa, K.; Ishii, Y.; Ogawa, M. Beziehungen zwischen der Stereoselektivität zweier Diels–Alder-Reaktionen und den Molekularrefraktionen Zahlreicher Lösungsmittel. *Tetrahedron* **1976**, *32*, 1427–1429.
- Cativiela, C.; García, J. I.; Gil, J.; Martínez, R. M.; Mayoral, J. A.; Salvatella, L.; Urieta, J. S.; Mainar, A. M.; Abraham, M. H. Solvent Effects on Diels–Alder Reactions. The Use of Aqueous Mixtures of Fluorinated Alcohols and the Study of Reactions of Acrylonitrile. *J. Chem. Soc., Perkin Trans. 2* **1997**, 653–660.
- Blankenburg, B.; Fiedler, H.; Hampel, M.; Hauthal, H. G.; Just, G.; Kahlert, K.; Korn, J.; Müller, K.-H.; Pritzkow, W.; Reinhold, Y.; Röllig, M.; Sauer, E.; Schnurpfeil, D.; Zimmermann, G. Über die Anwendung linearer Freier-Energie-Beziehungen auf Diels–Alder-Reaktionen. *J. Prakt. Chem.* **1974**, *316*, 804–816.
- Karcher, T.; Sicking, W.; Sauer, J.; Sustmann, R. Solvent Effects on Endo/Exo Selectivities in (4+2) Cycloadditions of Cyanoethylenes. *Tetrahedron Lett.* **1992**, *33*, 8027–8030.
- Blake, J. F.; Lim, D.; Jorgensen, W. L. Enhanced Hydrogen Bonding of Water to Diels–Alder Transition States. Ab Initio Evidence. *J. Org. Chem.* **1994**, *59*, 803–805.

- (35) Cativiela, C.; Dillet, V.; García, J. I.; Mayoral, J. A.; Ruiz-López, M. F.; Salvatella, L. Solvent Effects on Diels–Alder Reactions. A Semiempirical Study. *J. Mol. Struct. (THEOCHEM)* **1995**, *331*, 37–50.
- (36) Nakagawa, K.; Iwase, S.; Ishii, Y.; Hamanaka, S.; Ogawa, M. L'Influence du Solvant sur la Stéréosélectivité et la Régiosélectivité dans la Réaction de Diels–Alder entre le trans-Pentadiène-1,3 et l'Acrylonitrile. *Rev. Roum. Chim.* **1979**, *24*, 613–617.
- (37) Belluš, D.; von Bredow, K.; Sauter, H.; Weis, C. [4+2]-Cycloadditionen von 1,2-Dicyanocyclobuten und seine thermische Ringöffnung zum 2,3-Dicyanobutadien-1,3. *Helv. Chim. Acta* **1973**, *56*, 3004–3038.
- (38) Kobuke, Y.; Fueno, T.; Furukawa, J. The endo Selectivities of Some Methyl-Substituted Dienophiles in Diels–Alder Reactions with Cyclopentadiene. *J. Am. Chem. Soc.* **1970**, *92*, 6548–6553.
- (39) March, J. *Advanced Organic Chemistry*, 4th ed.; John Wiley: New York, 1992; p 145.
- (40) Baldwin, J. E.; Reddy, V. P. Stereochemistry of the Diels–Alder Reaction of Butadiene with Cyclopropene. *J. Org. Chem.* **1989**, *54*, 5264–5267.
- (41) Apeloig, Y.; Matzner, E. Evidence for the Dominant Role of Secondary Orbital Interactions in Determining the Stereochemistry of the Diels–Alder Reaction: The Case of Cyclopropene. *J. Am. Chem. Soc.* **1995**, *117*, 5375–5376.
- (42) Imade, M.; Hirao, H.; Omoto, K.; Fujimoto, H. Theoretical Study of Endo Selectivity in the Diels–Alder Reactions between Butadienes and Cyclopropene. *J. Org. Chem.* **1999**, *64*, 6697–6701.
- (43) Sodupe, M.; Rios, R.; Branchadell, V.; Nicholas, T.; Oliva, A.; Dannenberg, J. J. A Theoretical Study of the Endo/Exo Selectivity of the Diels–Alder Reaction between Cyclopropene and Butadiene. *J. Am. Chem. Soc.* **1997**, *119*, 4232–4238.
- (44) Jursic, B. S. A Density Functional Theory Study of Secondary Orbital Overlap in Endo Cycloaddition Reactions. An Example of a Diels–Alder Reaction between Butadiene and Cyclopropene. *J. Org. Chem.* **1997**, *62*, 3046–3048.
- (45) Jursic, B. S. The Importance of Secondary Orbital Interactions in the Stabilization of Isomeric Transition State Structures in the Cyclopropene Addition to Furan. *Tetrahedron Lett.* **1997**, *38*, 1305–1308.
- (46) Allen, B. F.; Lommerse, P. M.; Hoy, V. J.; Howard, J. A. K.; Desiraju, G. R. The Hydrogen-Bond C–H Donor and π -Acceptor Characteristics of Three-Membered Rings. *Acta Crystallogr.* **1996**, *B52*, 734–745.
- (47) Jursic, B. S. Suitability of Furan, Pyrrole and Thiophene as Dienes for Diels–Alder Reactions Viewed through their Stability and Reaction Barriers for Reactions with Acetylene, Ethylene and Cyclopropene. An AM1 Semiempirical and B3LYP Hybrid Density Functional Theory Study. *J. Mol. Struct. (THEOCHEM)* **1998**, *454*, 105–116.
- (48) Jursic, B. S. Governing Organic Reactions through Secondary Orbital Interactions. Semiempirical and Density Functional Theory Study of Catalyzed Cycloaddition Reactions between Pyrrole and Ether Dienophiles. *J. Chem. Soc., Perkin Trans. 2* **1999**, 373–378.
- (49) Bachrach, S. M. Diels–Alder Reaction of Furan with Cyclopropene. An ab Initio Study. *J. Org. Chem.* **1995**, *60*, 4395–4398.
- (50) Lee, M. W.; Herndon, W. C. Stereochemistry of the Furan–Maleic Anhydride Cycloaddition. *J. Org. Chem.* **1978**, *43*, 518.
- (51) Zhulin, V. M.; Bogdanov, V. S.; Kel'tseva, M. V.; Kabotyanskaya, E. B.; Koreshkov, Yu. D. Effect of High Pressure on the Composition of Stereoisomers from the Diels–Alder Reaction of Furan with Maleic Anhydride (in Russian). *Izv. Akad. Nauk SSSR, Ser. Khim.* **1989**, 2510–2517; *Chem. Abstr.* **1990**, *112*, 197262x.
- (52) Zhulin, V. M.; Kel'tseva, M. V.; Bogdanov, V. S.; Koreshkov, Yu. D.; Kabotyanskaya, E. B. Effect of High Pressure on the Rate Constant of the Diels–Alder Reaction between Furan and Maleic Anhydride. *Izv. Akad. Nauk SSSR, Ser. Khim.* **1990**, 525–529 (in Russian); *Chem. Abstr.* **1990**, *113*, 39655u.
- (53) Hoffmann, R.; Minkin, V. I.; Carpenter, B. K. Ockham's Razor and Chemistry. *Hyle* **1997**, *3*, 3–28.

AR0000152